

## For Immediate Release

*For more information contact:*

Lenora Campos, Ph.D.  
917.237.0665 x3104  
[lcampos@totousa.com](mailto:lcampos@totousa.com)  
Min Tak  
212.819.4807  
[Min.Tak@edelman.com](mailto:Min.Tak@edelman.com)

## **TOTO Re-Engineers Its Celebrated Line of EcoPower Flush Valves**

*Company introduces Technological Advances and Dramatically Increases Ease of Installation for World's First Water-Powered Flush Valves*

*(Morrow, GA) January 19, 2016* — TOTO continues the revolution in aqua-electronic technology by re-engineering its EcoPower high-efficiency flush valves for toilets and urinals, dramatically enhancing their effectiveness and ease of installation.

### **Harnessing the Power of Water in Motion**

TOTO's handsome chrome flush valves (also available as concealed units) generate their own power each time water spins a small internal turbine when the unit is flushed. Stored in a series of capacitors, this auto-generated electrical energy powers the flush valves' sensor eye, microprocessor, and solenoid. There is no need to hard wire them to a building's electrical system (which significantly increases installation cost) or for routine disposable battery replacement (an ongoing maintenance expense harmful to the environment).



### **Re-Engineered Valve Platform**

TOTO has enhanced its EcoPower flush valves with technological innovations that dramatically improve their hydropower technology's effectiveness. The redesigned EcoPower flush valve platform eliminates the need for daily use to power the flush valves' operation.

### **Sensor Enhancement**

The EcoPower flush valve's self-adjusting sensor does not require manual calibration, thereby providing fast and easy installation. The sensor's detection beam pulses, instead of monitoring continuously, removing

unnecessary strain on the sensor eye. To conserve its self-generated energy, the EcoPower flush valve records its usage patterns, then reduces its beam cycles during non-peak use periods.

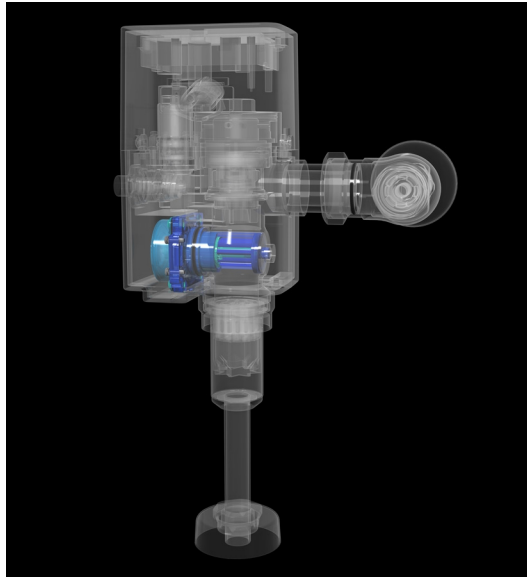

### **Superior Piston and Valve Design**

For its EcoPower flush valves, TOTO has engineered a piston design made from chemically-resistant POM plastic resin that will not allow scale or water treatments to damage its body; therefore, the piston's anticipated life expectancy is significantly longer than current bronze models. Its piston valve technology is a marked improvement over traditional rubber diaphragm type valves. Longer piston travel and self-cleaning 360° debris screen reduce common problems such as continuous running and flooding. The piston seat will not warp or mis-seal, significantly reducing repair and maintenance costs. With each activation, a micro-porous cup seal keeps the piston self-lubricated, using the incoming water supply.

### **Neutral Rough-In**

TOTO EcoPower flush valves have a neutral rough-in.

They can be used in a right or left rough-in with no modification.

### **Reducing Hazardous Waste**

Replacing sensor flush valves' disposable batteries costs time and money—and generates hazardous battery waste, which is harmful to the environment. TOTO's re-engineered EcoPower flush valves' store their self-generated electrical energy in a series of capacitors, eliminating the need for disposable battery replacement, which helps reduce toxic battery waste. By installing EcoPower flush valves, plumbing engineers and building maintenance teams no longer have to worry about budgeting for disposable batteries, battery shelf life, or low-quality batteries and their short life span. Plus, EcoPower flush valves do not contribute to hazardous battery pollution.

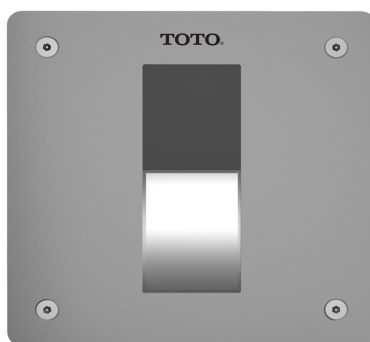

### **New Designs for the Exposed Valve and Concealed Valve Faceplates**

TOTO designs the outside of every product as the company innovates the technology inside. Inspired by long-view trends in global design, and what people need and want in its products, TOTO integrates form and function for the ultimate bathroom experience. The designs for the new exposed valve and concealed valve faceplates are classically modern with a clean, uncomplicated look. They integrate beautifully with the other products in the bathroom's interior design.

*Journalist's Note: As with all TOTO products, high-resolution digital photographs of the EcoPower Flush Valves are immediately upon request.*

### **About TOTO**

TOTO USA is headquarters for the Americas Division of the TOTO Global Group, which was established in 1917 with the founding of TOTO, Ltd., in Kitakyushu, Japan. TOTO is the world's largest manufacturer of bathroom fixtures and fittings with \$5.1 billion dollars in annual sales. For nearly 100 years, TOTO has been the recognized leader in performance innovation and design with products that enhance the luxury bathroom experience. Today, the company maintains 25,700 employees in 69 offices around the world and owns manufacturing facilities in Japan, Mexico, the USA, China and Europe with an affiliated network of more than 80 production facilities worldwide. With over 1,500 engineers on staff and three centers devoted to research and development, TOTO is dedicated to engineering products that respect the environment while meeting people's needs for comfort, beauty and performance. TOTO's corporate philosophy — People-First Innovation — is the guiding principle for all the company's processes, from engineering and design to manufacturing and sales. Consumers enjoy the peace of mind that comes from knowing they purchased a brand that innovates to improve people's quality of life. Winner of numerous domestic and international awards and recognitions, TOTO is the only plumbing manufacturer honored as Water Efficiency Leader by the U.S. Environmental Protection Agency. The company continues to raise industry standards and consumer expectations as to what is possible in the bathroom, as TOTO believes a high-quality bathroom is an experience and an everyday luxury people value and appreciate.

For more information, consumers may visit [www.totousa.com](http://www.totousa.com) or call 1.888.295.8134, Option 5. Follow TOTO on [Twitter](#) (@TOTOUSA) and become a TOTO fan on [Facebook](#)

# # #